

R22[®] BETA II



ROBINSON HELICOPTER COMPANY

R22 BETA II HELICOPTER



The **ROBINSON® R22 BETA II** is a two place, light utility helicopter with responsive handling and quick maneuverability. Powered by a Lycoming O-360 four-cylinder engine, the R22's proven reliability, low maintenance, and low operating costs make it ideal for a variety of applications.

A powder-coated steel-tube structure gives the R22 a rigid yet lightweight airframe, while the aerodynamic fuselage optimizes airspeed and fuel economy. With a two-bladed rotor system, the R22 requires only one-third the hangar space of a multi-bladed helicopter.

FEATURES

LYCOMING O-360 ENGINE is derated to 131 horsepower for take-off and 124 for cruise at 2652 RPM, giving the engine long life and unmatched reliability.

AUTOMATIC CLUTCH ENGAGEMENT simplifies the starting procedure and reduces the possibility of overspeed during startup.

CARBURETOR HEAT ASSIST enhances safety and reduces pilot workload by automatically adding carb heat when the collective is lowered and reducing carb heat when the collective is raised.

RPM GOVERNOR monitors engine speed and adjusts the throttle automatically to maintain optimal RPM.

CENTER-POSITIONED CYCLIC

Robinson's center-positioned teetering T-Bar cyclic makes it easy to enter and exit the cockpit. Left-seat flight controls are removable.

PISTOL-GRIP CYCLIC

Ergonomic grips incorporate two-position trigger switches for intercom and transmit. Pilot-side grip features buttons for convenient switching of COM frequencies.

R22 BETA II



TRI-HINGE ROTOR HUB eliminates lag hinges, dampers, and hydraulic struts. Blades have a stainless steel spar at the leading edge which resists erosion. Droop stops prevent excessive main rotor teetering while stopping or starting under normal operating conditions.

ROTOR BRAKE allows the pilot to stop the rotor quickly, reducing shutdown time and the risk of injury to ground personnel and passengers.

AIR VENTS in the cabin provide fresh air for pilot and passenger.

VOICE-ACTIVATED INTERCOM eliminates the need to use intercom switches during doors-on flights. Floor and hand intercom switches are included for doors-off operations.

GROUND HANDLING is made easy with ground handling wheels. A tow cart adaptor is included for use with Robinson's optional Electric Tow Cart.

STORAGE under each seat allows for carry-on bags, briefcases, and personal belongings.



Under-seat storage compartment

MAINTENANCE is simplified, requiring only oil changes between 100-hour inspections. Main and tail rotor drive systems use maintenance-free flexible couplings in place of universal joints or gear couplings. Primary controls are actuated by push-pull tubes and bell cranks, eliminating cables and pulleys. Teflon-lined bearings eliminate periodic lubrication requirements.

TIME BETWEEN OVERHAUL (TBO)

Properly maintained, the R22 has an approved engine and airframe TBO of 2200 hours or 12 years. All life-limited components have approved service lives of at least 2200 hours or 12 years.

WORLDWIDE SERVICE is readily available with factory-trained technicians at more than 400 Robinson-approved service centers throughout the world.

WARRANTY

The R22 comes with a two-year or 1000-hour limited aircraft warranty.

COCKPIT



OPTIONAL UPGRADES

- **CABIN HEATER & DEFOGGER SYSTEM**
- **LEATHER SEATS** available in tan, blue, and gray.
- **BOSE A20 AVIATION HEADSETS** with active noise reduction and Bluetooth communications interface.
- **ENGINE PRIMING SYSTEM**
- **XENON HID LANDING LIGHTS**
Xenon High Intensity Discharge (HID) lights provide superior illumination. HID bulb life exceeds 2000 hours.

R22 BETA II HELICOPTER

SPECIFICATIONS	
Engine Type	Lycoming O-360, four-cylinder, carbureted
Horsepower	Derated to 131 hp for take-off and 124 for cruise
Max Gross Weight	1370 lb
Approximate Empty Weight (incl oil & std avionics)	855 lb
Standard Fuel (19.2 gal)	115 lb
Auxiliary Fuel (10.5 gal)	63 lb
Passengers and Baggage with Standard Fuel	400 lb
Max Airspeed (Vne)	102 kts (118 mph)
Cruise Speed	up to 96 kts (110 mph)
Max Range (w/aux fuel)	approx 260 nm (300 sm)
Hover Ceiling IGE @ 1370 lb	9400 ft
Hover Ceiling OGE @ 1300 lb	8000 ft
Max Operating Altitude	14,000 ft
Electrical System	14V

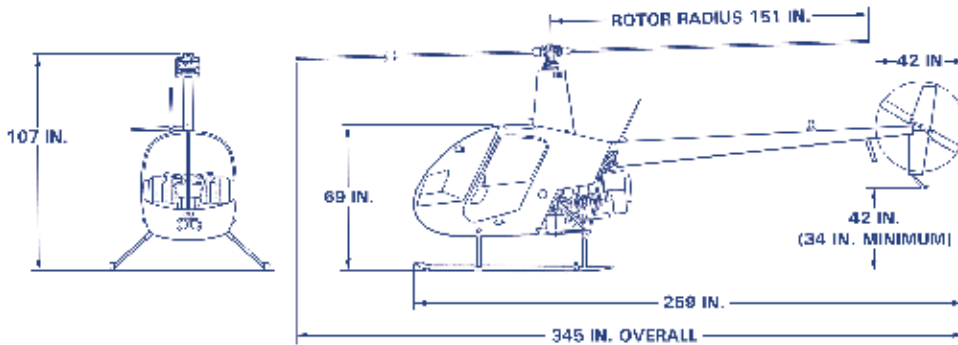
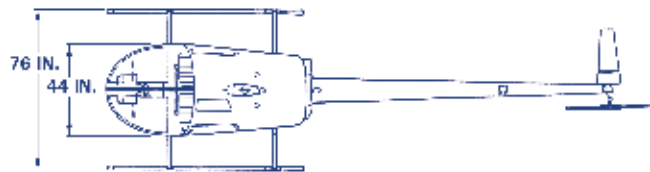

STANDARD INSTRUMENTS

- Airspeed indicator
- Altimeter (in-Hg)
- Rotor/engine dual tachometer
- Manifold pressure gage
- Vertical speed indicator
- Magnetic compass
- Cylinder head temperature gage
- Oil temperature & pressure gages
- Fuel quantity gages
- Ammeter
- Carburetor temperature gage
- Quartz clock
- Digital OAT gage/voltmeter
- Hourmeter

WARNING LIGHTS

- Alt low voltage
- Low fuel
- Low oil pressure
- Low rotor RPM (light and horn)
- Main gearbox temperature
- Main gearbox chip
- Tail gearbox chip
- Rotor brake engaged
- Starter engaged
- Clutch actuator
- Governor off

STANDARD EQUIPMENT

- Anti-collision light
- Dual landing lights
- Navigation, panel, and map lights
- Auxiliary fuel system
- Door locks
- Floor and hand intercom switches
- Tinted windshield and windows
- Belly hardpoint
- Tow cart adapter
- Oil filter and engine oil quick drain
- Ground handling wheels
- Rotor blade tie downs
- Windshield cover
- Robinson travel bag

QUALITY MANUFACTURING



Robinson's 617,000 square foot facility.

Robinson manufactures, assembles, inspects, and flight tests all of its helicopters at its Torrance, California factory. State-of-the-art equipment is utilized to manufacture the majority of parts in-house, allowing Robinson to maintain a high level of quality control and eliminate unnecessary costs.

ROBINSON HELICOPTER COMPANY

2901 Airport Drive • Torrance, CA • 90505 • USA

Phone: 310-539-0508 • Fax: 310-539-5198

www.robinsonheli.com